



**FIT-RIGHT**<sup>®</sup>  
SINCE 1968

**Fit-Right Storage Systems**  
Consult | Design | Execute

[www.fitright.in](http://www.fitright.in)





## Product Range

- Slotted Angle Filling Racks
- Slotted Angle Storage Racks
- Slotted Angle Frame Works Racks
- Heavy Duty Slotted Angle Racks
- Two Tyre Racking Systems
- Heavy Duty Slotted Angle Mezzanine Floor
- Pallet Racks
- Drive Through Pallet Racks
- Storwels
- Industrial Lockers

And many more customised options...

## Industries Catering To

- Automobile
- Textile
- Pharmaceutical
- Garments
- Medical
- Electronics
- Food & Beverages
- Hospitality
- Footwear
- Paper & Allied Industry
- I.T. Industry
- Construction
- Airports
- Logistics
- Warehousing Industry
- E-Commerce

And many more...



# OUR REACH

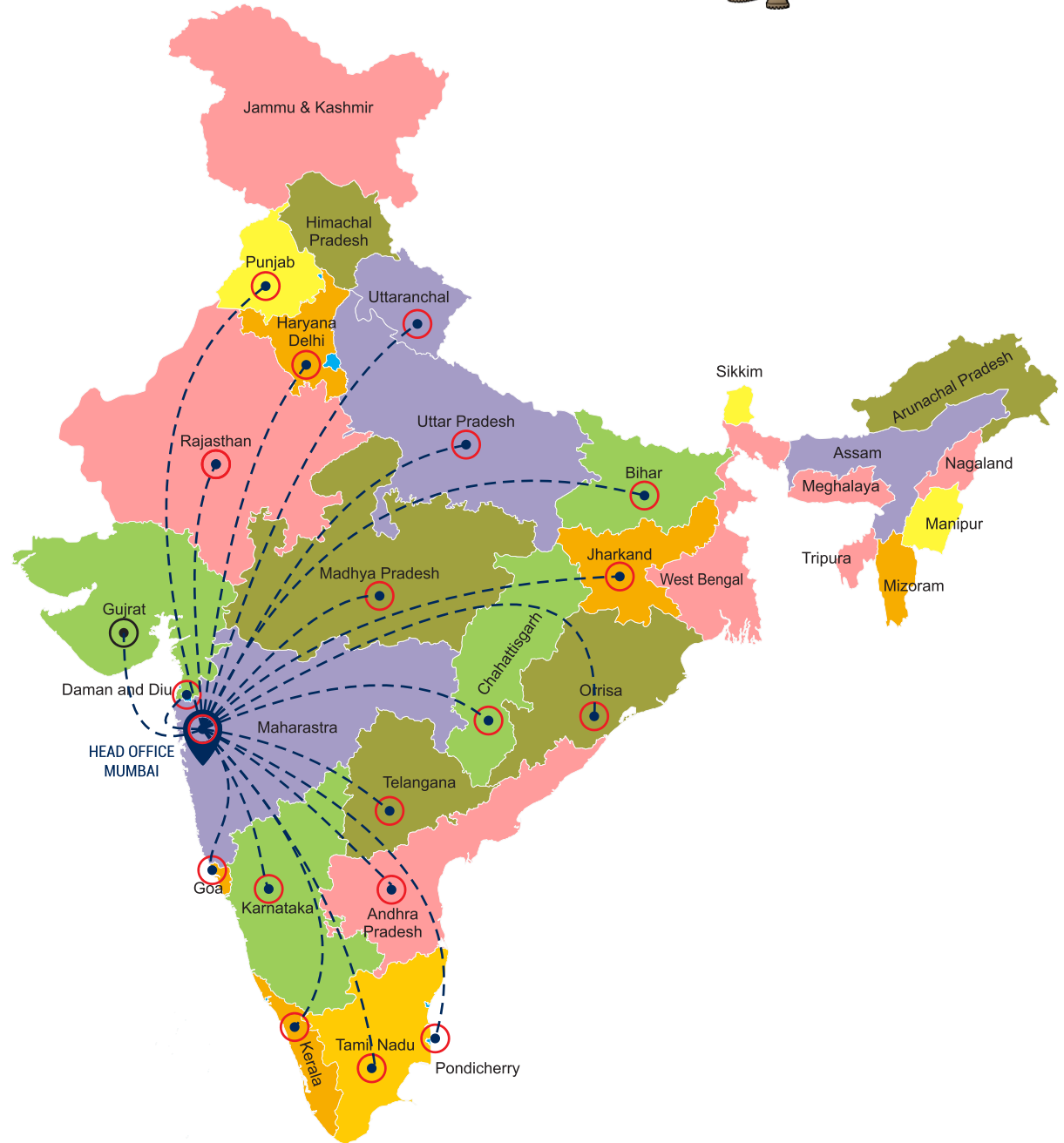
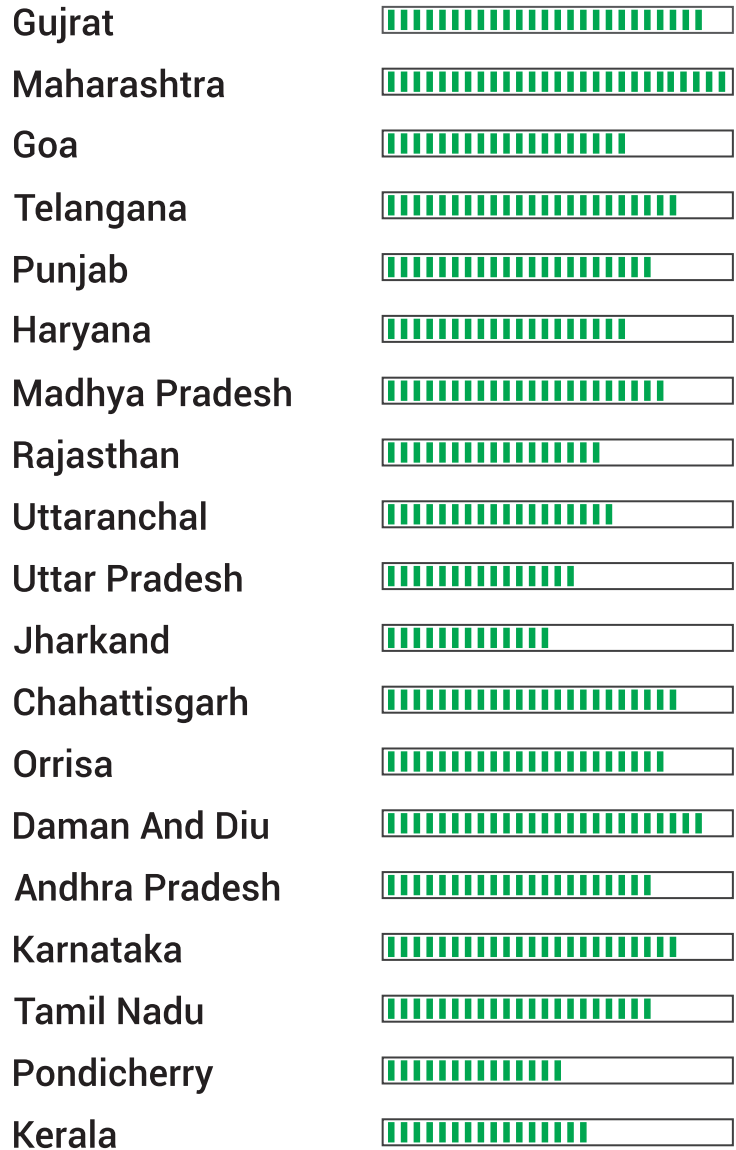





## ABOUT US



Since our inception in **1968** we have been very sensitive in understanding and responding to the requirements from the market which has considerably increased our offerings. We love bringing forth solutions for your concerns and offer cost-effective and end-to-end solutions with products ranging from Slotted Angle Shelving, Selective Pallet Racking to integrated man-less intelligent Warehousing Solutions.

**FIT-RIGHT STORAGE SYSTEMS** is highly export oriented with capabilities benchmarked with global standards in design, manufacturing, project management, distribution and sales support.

We have our well-established presence in regions like SAARC, South East Asia, Middle East and Africa. Our export business is our high growth area hence all our people and processes continuously endeavor to excel in international business by meeting and exceeding the customer and distributor expectations. This has been utilized to lead our development activity in domestic operations in terms of offering our products with continuous bench-marking.

**FIT-RIGHT STORAGE SYSTEMS** makes your life organized and easy with its expertise in the field of racking and storage systems. We are pioneers, visionaries and market leaders for over 5 decades in India in the field of Storage System & Material Handling with world-class design, manufacturing, project management, distribution & after sales support to service all your needs.



## OUR ACHIEVEMENTS

- ▶ 1968 – First Large Business House To Enter The Field Of Material Handling & Storage System.
- ▶ 1972 – First Organization To Have 4 Fully Equipped Plants In India.
- ▶ 2000 – Set Up New State-of-art Manufacturing Plant In Chandigarh.
- ▶ 2001 – Pioneers In Getting High Rise Pallet Racking System In India .
- ▶ 2002 – Pioneers To Introduce Multi Bend Roll Formed Profiles (India).
- ▶ 2004 – Installed 2098 Racks In Baddi ( Largest Job In The History Of This Industry)
- ▶ 2005 – Pioneers In Warehouse Consulting In India.
- ▶ 2008 – Exports Grow To Rs 20+ Cr With Breakthrough In New Markets.
- ▶ 2010 – Opened Our Flagship Showroom In Bhiwandi
- ▶ 2014 - 1st Organization In The World To Open E-commerce Website To Sell Storage Systems Online In India .

## FIT-RIGHT STORAGE SYSTEM



- Available Storage Space
- Required Storage Space

### CONSULT



### DESIGN



### EXECUTE

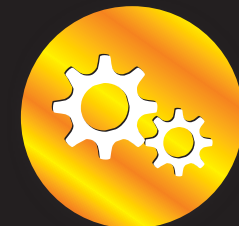



## WHY STORAGE SYSTEM

India has recently emerged as one of the main economic hubs in the world standing equal to other superpower countries. India has slowly opened up its markets through economic liberalization. The economy of India is the tenth largest in the world by nominal GDP and the third largest by purchasing power parity. However, for every industry to prosper there is a need for proper establishments and organised storage space in demanding markets, which has become a challenge in today's competitive world.

The escalating price of the space/property plays a vital role in making decisions for expanding your business. The products need to be stored and organized in a proper way which will not only help to maintain the quality and condition of the products but also save execution time. As the value for the space is growing at a high pace there is a need for smarter storage solutions. Our expert consulting & design team make it easy to identify the correct required storage system for optimizing the space in order to make optimum use of it in a given limited space.

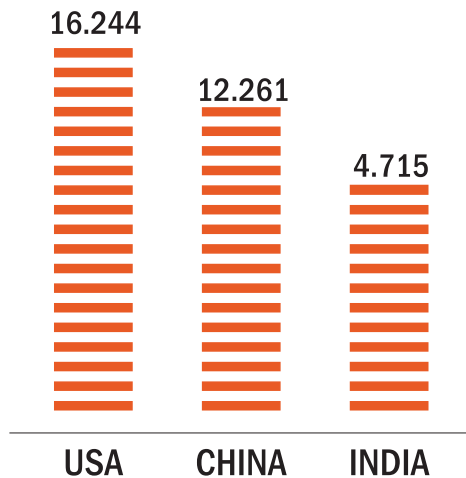

INDIA - 3rd Largest By Purchasing Power Parity

- ≡ Available Storage Space
- ≡ Required Storage Space

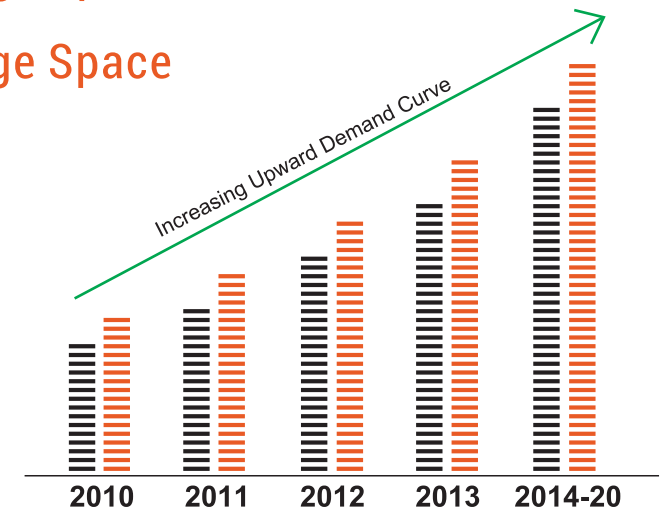



# WHY FIT-RIGHT STORAGE SYSTEM



## Our credentials include the following :

All our components are designed to the best quality standards conforming to the current Indian Standards and are also in line with the guidelines/standards enumerated in RMI and SEMA.

Our solutions are also tested through FEA for structural rigidity and safety thus producing designs, which are safe and efficient. Our design analysis and development activities are well supported by advanced software packages like, ANSYS, IDEAS, and AUTO-CAD.

Continuous Product improvements and new product development utilizing exclusive prototyping facilities and academic industry partnerships makes us a unique player in this field with an ability to cater to wider spectrum of industries and applications.

## Manufacturing Capabilities :

Best in class manufacturing technology and deployment that includes Multiple Roll Forming lines to form various components, we have Automated Powder Coating line and Semi automated Welding Automation systems. We have the capability to paint /powder coat single component up to 9 meters in length. We have one of the largest manufacturing capacity in India with high flexibility and capability to execute large projects and offer customized solutions as per the needs of the customers in domestics as well as international markets.

## Reach & Distribution :

The guiding principle at **FIT-RIGHT STORAGE SYSTEMS** is customer service and all our efforts are directed towards achieving highest standards of the same. Our products are backed by a very strong company sales and service establishments throughout the country as well as in strategic export market.

## Design Excellence :

Our Design capability with global benchmarks provide efficient as well as customized solutions for all customer applications utilizing advance technologies, knowledge base and understanding of industry applications. Our design analysis and development activities are well supported by advanced software packages like, ANSYS, IDEAS, and AUTO-CAD.

## Quality Assurance :

The raw material used for the manufacturing is subjected to sample test as per plan to ensure that the same is as per requirement. This is over and above the test certificates, which are provided by the steel manufacturer.

The steel used is certified for its chemical composition by respective chemical analysis and the mechanical properties like yield-strength by standard physical testing methods. The powder meant for finish is tested for its chemical and physical properties for every batch.

The fasteners also undergo random sampling tests for its dimensions. We have well established in-process and final quality test methods to ensure that all the products manufactured conform to standards of quality, which is benchmarked with International offerings.

On site our technical engineers supervise the site to make sure that the fitting contractors do the correct installation as per the generated design. Our engineers use most advanced methods to check the alignment and stability of the structure installed.

## SLOTTED ANGLES & ALLIED PRODUCTS

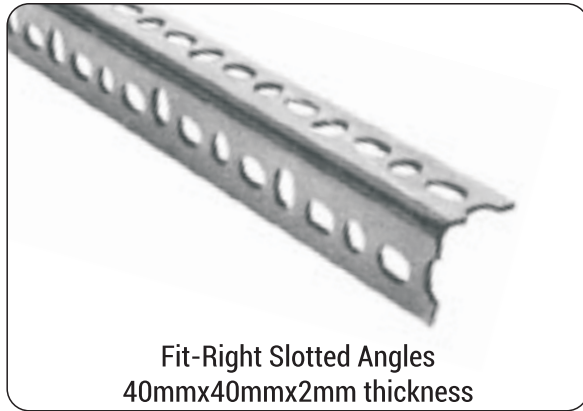

Fit-Right Slotted Angles  
40mmx40mmx2mm thickness

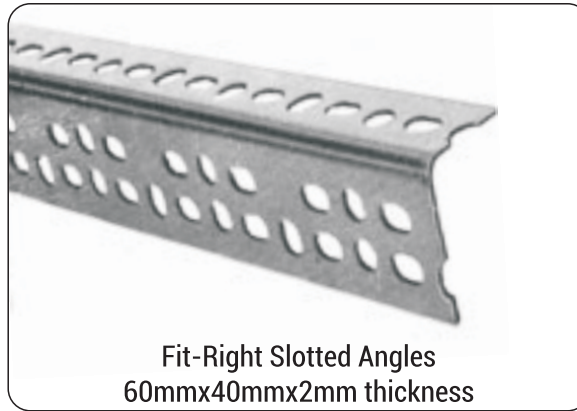

Fit-Right Slotted Angles  
60mmx40mmx2mm thickness

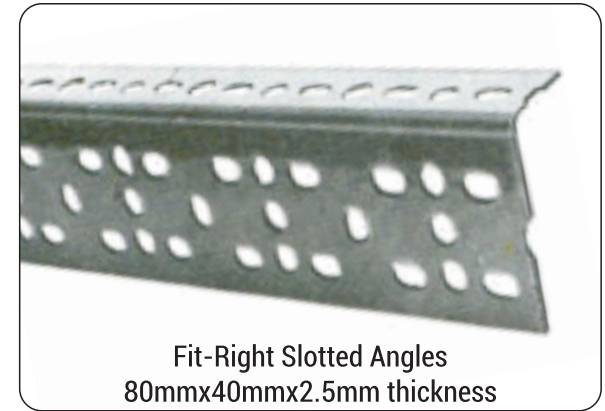

Fit-Right Slotted Angles  
80mmx40mmx2.5mm thickness

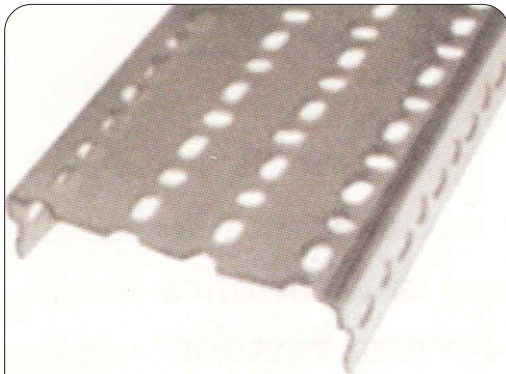

Fit-Right Channel  
40mmx75mmx40mmx2mm/2.5mm  
40mmx150mmx40mmx2mm/2.5mm

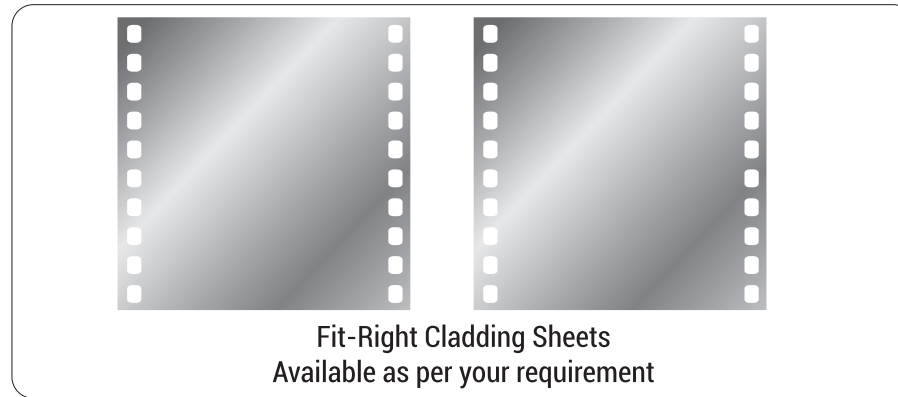

Fit-Right Cladding Sheets  
Available as per your requirement



Fit-Right Shelves  
20g & 18g also size can be made  
according to your specification's as well

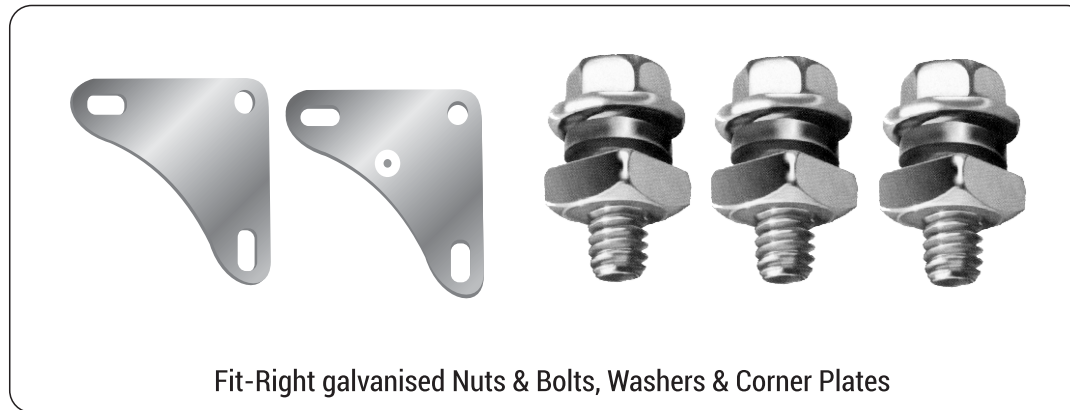

Fit-Right galvanised Nuts & Bolts, Washers & Corner Plates



# SLOTTED ANGLE & ALLIED PRODUCTS

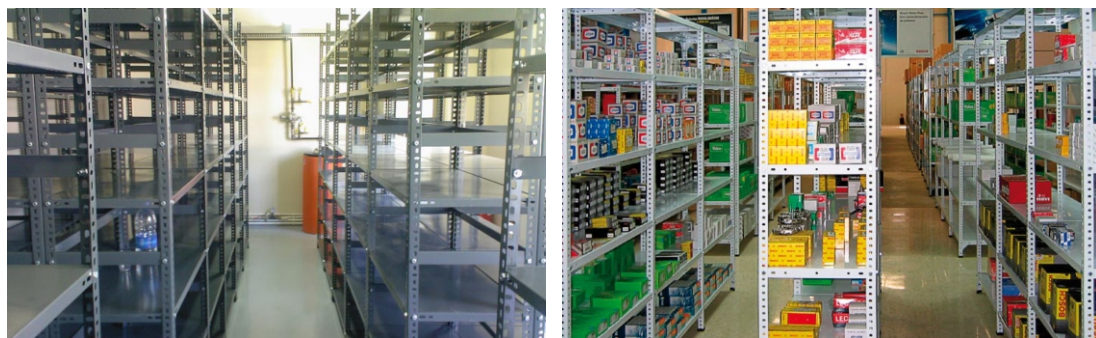



## MULTI TIER RACKS



## SLOTTED ANGLE MEZZANINE FLOORS





## SLOTTED ANGLE WORK BENCHES



## SLOTTED ANGLE PARTITIONS



# HEAVY DUTY PALLET RACKING

1. Splice
2. Straddle beam
3. Beam
4. Steel straddle beam
5. Tie bar protractor
6. Beam protractor
7. Slant brace
8. Base plate
9. Special shelving
10. Upright
11. Crash proof handrail
12. Crash proof of foot protector
13. N-model bracket
14. C-model shelving
15. Board
16. Fixed plates of Bed board
17. □-model steel plate
18. Tie bar

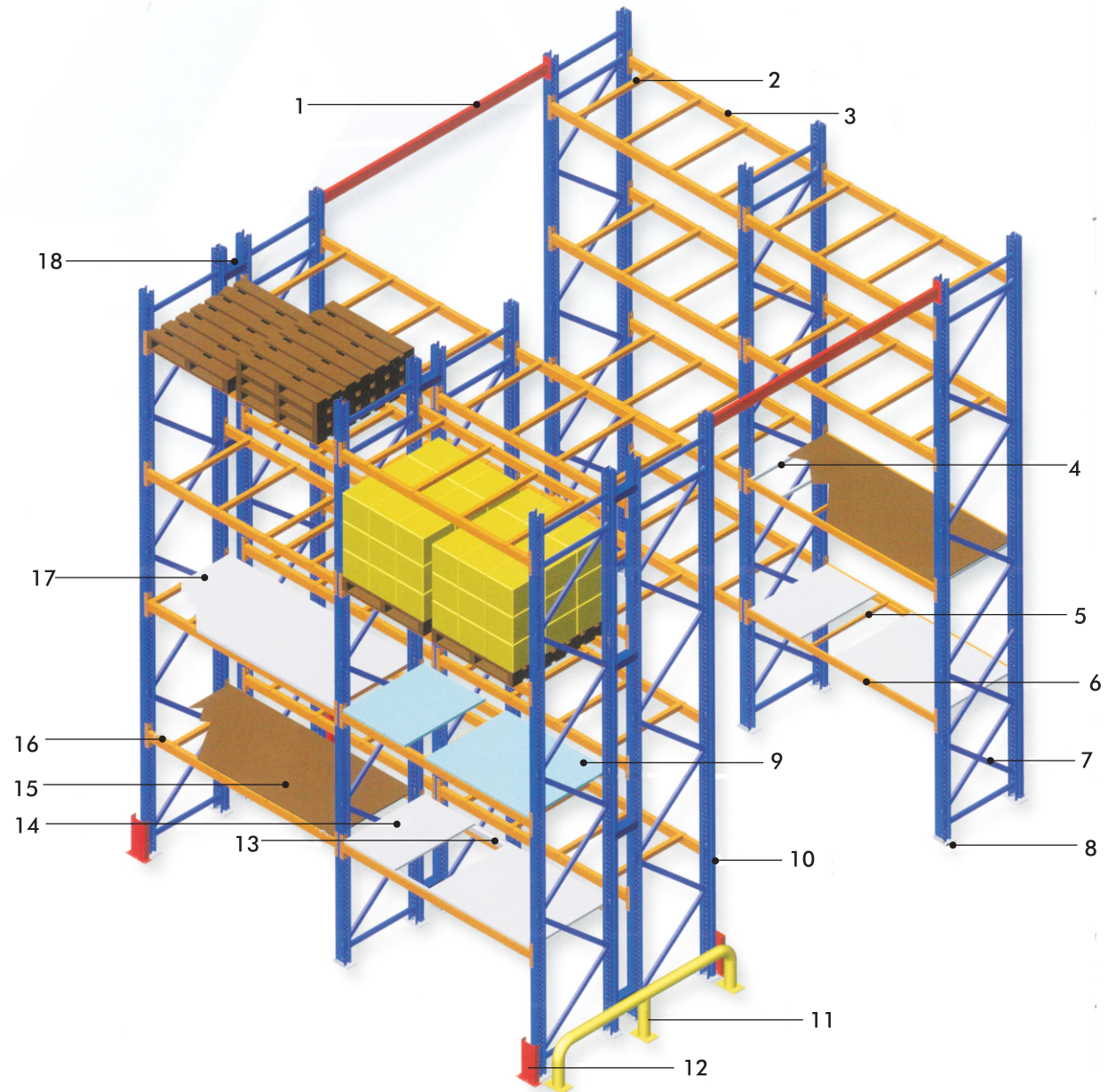



## HIGH RISE STORAGE SOLUTION

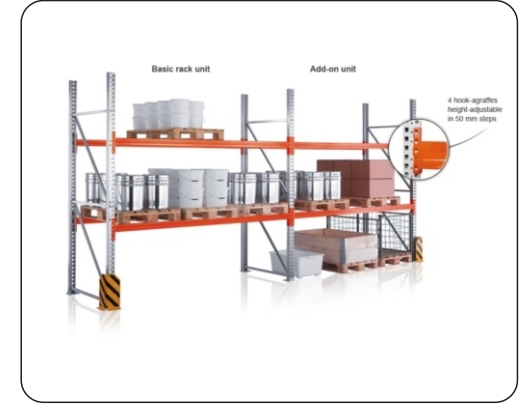

## MEDIUM DUTY RACKS





## DRIVE -IN/DRIVE - THROUGH PALLET RACKS

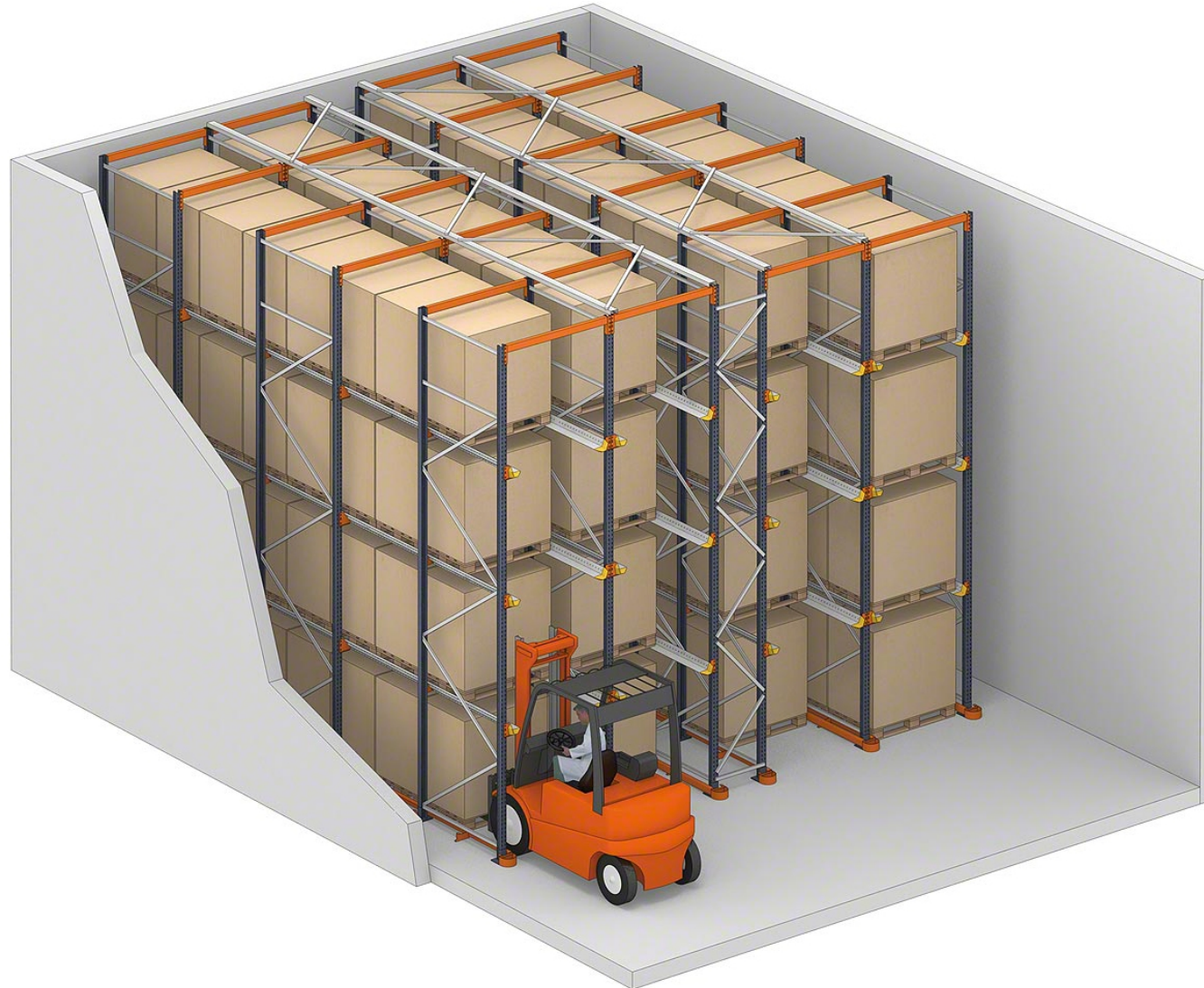



## CANTILEVER PALLETS

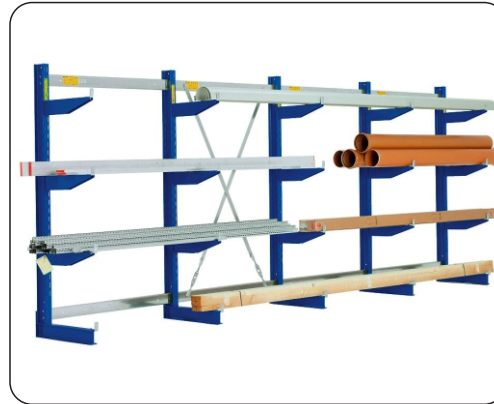

## DRIVE - IN / DRIVE - OUT

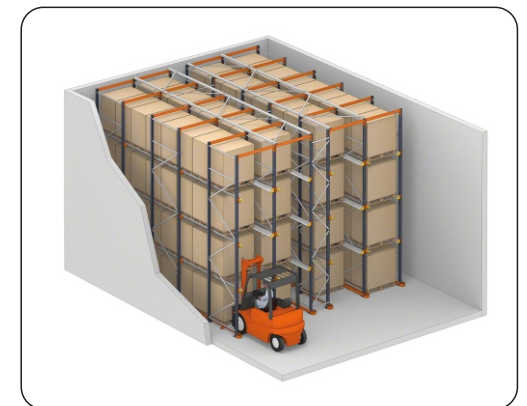
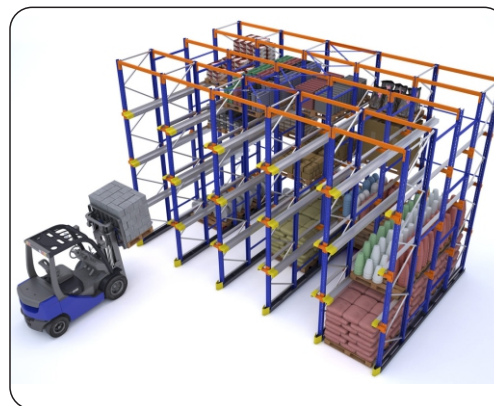
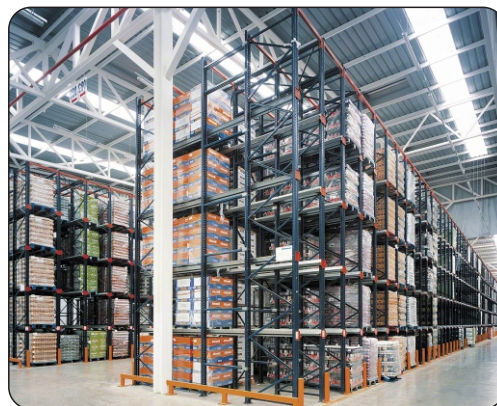

## METAL PALLETS



## WOODEN PALLETS





## PLASTIC BINS

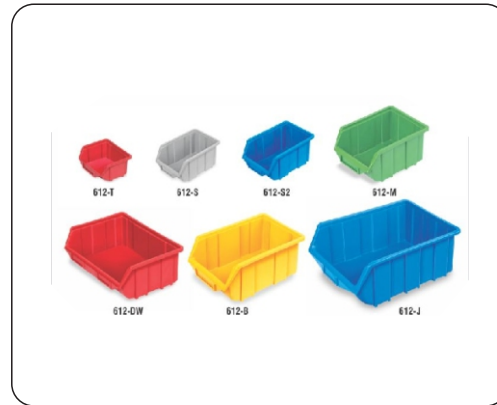

## INDUSTRIAL LOCKERS



CIL-01

CPL-01



CIL-02

CPL-02



CIL-03

CPL-03



CIL-04

CPL-04

## STOREWELL



CST-01



CST-03



CST-04



CST-06



# MOBILE COMPACTOR

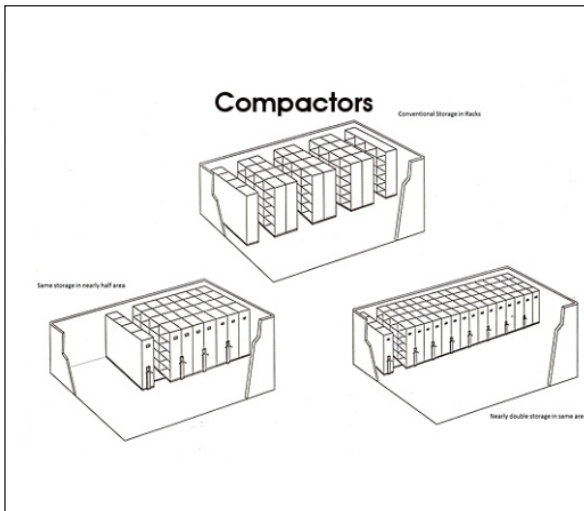
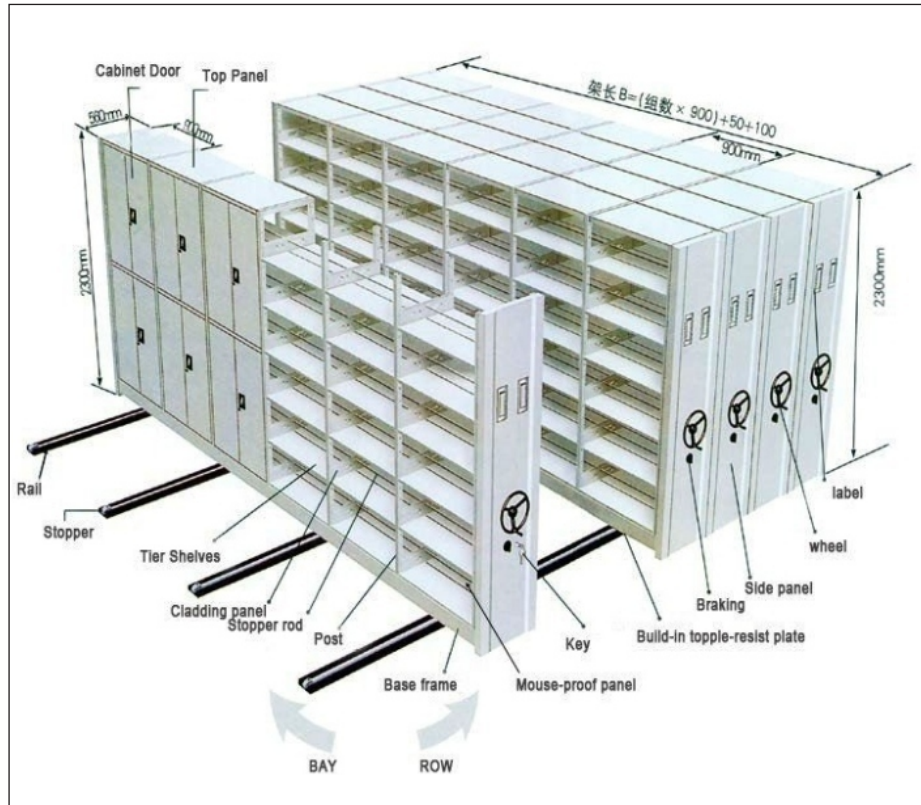



**FIT-RIGHT**  
SINCE 1968

Consult | Design | Execute

Warehousing Automation Partners



Lalesse



AN ISO 9001-2008 COMPANY  
LOGISTIC STORAGE SOLUTIONS  
Since 1991

**FIT-RIGHT STORAGE SYSTEMS**

Sales Office: 209-A, C-wing, Gokul Industrial Premises,  
2nd Floor, Sagbaug, Marol Co-op Industrial society,  
Andheri East, Mumbai-400059

Phone: 022- 40053777 / 40140666  
Mobile: 09820589554 Email: info@fitright.in /  
fitrightindia@gmail.com

www.fitright.in

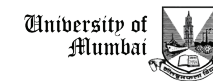

and many more...